

Movable Smart Road Divider to Avoid Traffic Problems

G Manasa, M Kalpana, J Pranathi, A Vaishnavi, K Tejaswini,
Prabhakara Rao Kapula,
B V Raju Institute of Technology, NARSAPUR, Telangana

Abstract: - *The issue with Static Road Dividers is that the number of paths on either side of the street is constant. Since the resources are constrained and population just as number of vehicles per family is expanding, there is huge increment in number of autos or cars on streets. This calls for better use of existing resources like number of paths accessible. Our aim is to formulate a mechanism of automated road divider that can shift lanes, so that we can have number of lanes in the direction of the rush. The cumulative impact of the time and fuel that can be saved by adding even one extra lane to the direction of the rush will be significant*

Key words: *Divider, Traffic, IR Sensors, Motor, Divider.*

Date of Submission: 25-04-2020

Date of Acceptance: 08-05-2020

I. Introduction

Road Divider is generically used for dividing the Road for ongoing and incoming traffic. This helps keeping the flow of traffic; generally, there is equal number of lanes for both ongoing and incoming traffic. The problem with Static Road Dividers is that the number of lanes on either side of the road is fixed. Since the resources are limited and population as well as number of vehicles per family is increasing, there is significant increase in number of vehicles on roads. This calls for better utilization of existing resources like number of lanes available. For example, in any city, there is industrial area or shopping area where the traffic generally flows in one direction in the morning or evening. The other side of Road divider is mostly either empty or very under-utilized. This is true for peak morning and evening hours. This results in loss of time for the car owners, traffic jams as well as under utilization of available resources.

With the smarter planet application proposed below, we will also eliminate the dependency on manual intervention and manual traffic coordination so that we can have a smarter traffic all over the city. An Automated road divider can provide a solution to the above-mentioned problem effectively. Here Low, Medium and High density of traffic value will be identified using IR sensors and lane will be moved using gear motors.

Countries around the world are day by day facing problem of traffic congestion due to increase in number of vehicles in society. Although the number of vehicles using the roads has increased, the static road infrastructure is almost the same and is unable to survive with changes like congestion, unpredictable travel-time delays and road-accidents that are taking a deal with study of traffic in Hyderabad and suggesting a movable traffic divider technique for the same which can be used irrespective of the topographical, climatic, geographical obstructions and in combination which can help us to solve the traffic congestion problem in an optimal manner. The theory is simple. Take the morning peak period. In many cities the most congested highways are main radial feeders channeling traffic into a downtown central business district. These roads often demonstrate unbalanced flows with perhaps 70% of traffic travelling inbound and only 30% – sometimes even less – travelling outbound. This scenario leads to recurring congestion in the peak direction but free-flow conditions counter-peak. If it was possible to inject some flexibility into the supply of highway capacity, the existing road space could be realigned to better match this profile of demand and an enhanced Level of service could be provided to drivers without building any extra capacity (additional lanes or new roads). Movable barrier technology does just that.

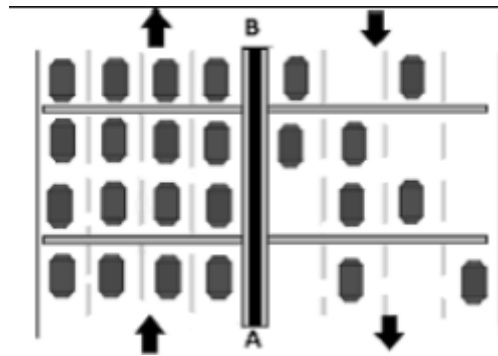

Fig 1. Road Divider

II. Literature Survey

The concept of movable road dividers was from the 90's, the reason was that there was traffic congestion from that period. At that period the machine was called as zipper machine, which is used to shift the divider from one lane to another lane. It was introduced in earlier 90's and the first working model of zipper machine was bought by Hawaii department of transport in late 90's. The machine contains a s-shaped inverted conveyor channel which lifts the barrier segment weighing almost 450kgs. The minimum length of the machine is 100feet. The barrier segment is attached to the machine and whenever there is traffic congestion the machine will move and along with the machine the barrier segment that contains the divider also moves resulting in the width of the lanes. In the proposed model, we are not using a machine and operating it manually rather operating it automatically by using two dividers namely normal and extended dividers. In this paper we place the ultrasonic sensor to one side of the road to detect whether there is any traffic congestion or not, if there is a congestion then the extended divider raises up and normal divider is set to ground level, else the normal divider is raised up and extended divider is set to ground level. And if there is congestion then a message is sent to the nearby traffic control police stating that traffic congestion has occurred. So this is simple and can replace the heavy machines.



Fig 2. Road Divider using vehicle

III. Proposed System

In this proposed system, a module has been developed based on microcontroller that consists of an IR sensor which is used for measuring the traffic density in this case and two dividers normal and extended. When the signal turns red, the traffic density is measured and the action should take place before the signals turn into green. If the traffic is high then the extended divider comes up and the normal divider goes to ground position. Since the traffic is high a message is display on LCD that 'Left side or Right-side traffic is high, extended divider is up' to the nearest traffic control room. If the traffic density is normal then no type of action is taken and the normal divider is up and the extended divider is to ground level. In this case the traffic density is normal then a message is delivered stating that 'Traffic is normal. Normal divider is up and the extended divider is to ground level' to the nearest traffic control room. Since it is a demo module, we are just showing for the one way of traffic flow

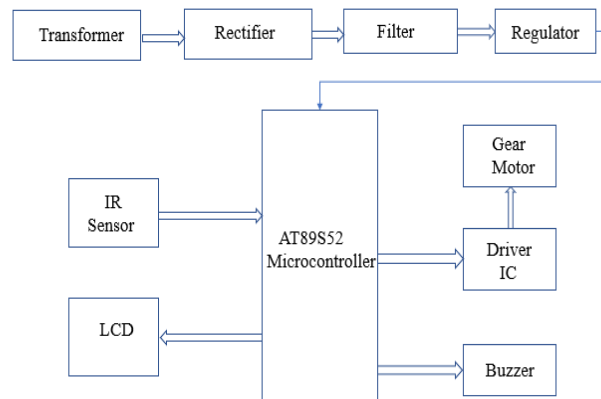

Fig 3. Proposed Road Divider

A. AT89S52

The AT89S52 is a low-power, high-performance CMOS 8-bit microcontroller with 8K bytes of in-system programmable Flash memory. The device is manufactured using Atmel’s high-density nonvolatile memory technology and is compatible with the industry-standard 80C51 instruction set and pin out. The on-chip Flash allows the program memory to be reprogrammed in-system or by a conventional nonvolatile memory programmer. By combining a versatile 8-bit CPU with in-system programmable Flash on a monolithic chip, the Atmel AT89S52 is a powerful microcontroller, which provides a highly flexible and cost-effective solution to many, embedded control applications.

B. IR SENSOR

An electroluminescent IR LED is a product which requires care in use. IR LEDs are fabricated from narrow band hetero structures with energy gap from 0.25 to 0.4 eV. That's why the bias used to initiate current flow is low compared to the well-known visible or NIR LEDs. Typical forward bias is $V \sim 0.1 - 1$ V only for mid-IR LEDs. Be sure not to exceed I^*max which is given in each LED specification and do not use test instrument that contain sources/batteries with voltage greater than $V_{cw} max$ given in specification. For LED current restriction and further LED current measurement we recommend to use resistor (1-5 Ohms) connected in serial to LED.

C. GEAR MOTOR

Gear motors are complete motive force systems consisting of an electric motor and a reduction gear train integrated into one easy-to-mount and -configure package. This greatly reduces the complexity and cost of designing and constructing power tools, machines and appliances calling for high torque at relatively low shaft speed or RPM. Gear motors allow the use of economical low-horsepower motors to provide great motive force at low speed such as in lifts, winches, medical tables, jacks and robotics. They can be large enough to lift a building or small enough to drive a tiny clock.

IV. Features

1. This proposed model can be operated automatically.
2. More organized traffic flow can be achieved, reducing traffic jams.
3. Based on the traffic density the time allotted for the passing of traffic is decided automatically.
4. Location Based Services can be done by means of enabled devices.

V. Conclusion

In this paper, we have designed and developed a ‘Automatic Movable Smart Road Divider to Avoid Traffic Problems’, in which the results are satisfactory. Since it is a demo model, we have only shown it through one way of traffic using IR sensors. It will help in to reduce the traffic At Banjara Hills and highway. Also, it is helpful for the government to apply traffic rules. And people will follow the rules of traffic. It’s applicable in almost all areas in the Hyderabad city. It will be applicable in the cross road and traffic zone. But in real time

traffic congestion can be in more than one direction, and then also this module can be used by using image processing rather than the basic sensors.

References

- [1]. K.Vidhya, A.BazilaBanu, Density Based Traffic Signal System", Volume 3, Special Issue 3, March 2019
- [2]. Priyanka Khanke, Prof. P. S. Kulkarni, "A Technique on Road Tranc Analysis using Image Processing", Vol. 3 Issue 2, February 2019.
- [3]. RajeshwariSundar, SanthoshsHebbar, and VaraprasadGolla, Implementing intelligent Traffic Control System for Congestion Control, Ambulance Clearance, and Stolen Vehicle Detection" IEEE Sensors Journal, Vol. 15, No. 2, February 2018
- [4]. Ms.PallaviChoudekar, Ms.SayantiBanerjee ,Prof.M.K.Muju, Real Time Traffic Light Control Using Image Processing" Vol. 2, No. March.
- [5]. ShabbirBhusari, "Traffic control system using Raspberry-pi", Global Journal of Advanced Engineering Technologies ISSN (Online), Volume 4, Issue 4- 2015, pp 413-415. 2016.
- [6]. S.Lokesh, "An Adaptive Traffic Control System Using atmega", International journal of engineering sciences & research Technology, IEEE conference June 2014, pp 831-835.
- [7]. SoufieneDjahel, "Reducing Emergency Services Response Time in Smart Cities: An Advanced Adaptive and Fuzzy Approach", IEEE 2015, pp 978- 986
- [8]. George Kiokes, "Development of an Integrated Wireless Communication System for Connecting Electric Vehicles to the Power Grid", IEEE conf. 2015, pp 296-301.
- [9]. Victor Welikhe, "Graph Neuron based Approach to Smart Roads Solutions using Wireless Sensor Networks", IEEE 2014, pp 275-279
- [10]. K Prabhakara Rao, Aadithyan V, T Sai Samrat Goud, G Karthik Reddy, P Naga Chaitanya, V Jaya Surya, IOSR Journal of Electronics and Communication Engineering (IOSR-JECE), Volume 14, Issue 5, 2019
- [11]. K.Prabhakara Rao, Bhanusri Tumma,Advanced car parking system with GSM supported slot messenger IOSR Journal of Electronics & Communication Engineering, 10 Issue 1 Pages 14-18, 2015

G Manasa, etal. "Movable Smart Road Divider to Avoid Traffic Problems." *IOSR Journal of Electronics and Communication Engineering (IOSR-JECE)* 15(2), (2020): 28-31.